

**United States Patent** [19]

[11]

**4,395,832**

**Jones et al.**

[45]

**Aug. 2, 1983**

[54] **GAS DUCT ARRANGEMENT FOR A**

4.259.088 3/1981 Moss ..... 34/57 A

**VACUUM FURNACE**

*Primary Examiner*—Larry I. Schwartz

**Rinlev. Perkasio both of Pa**

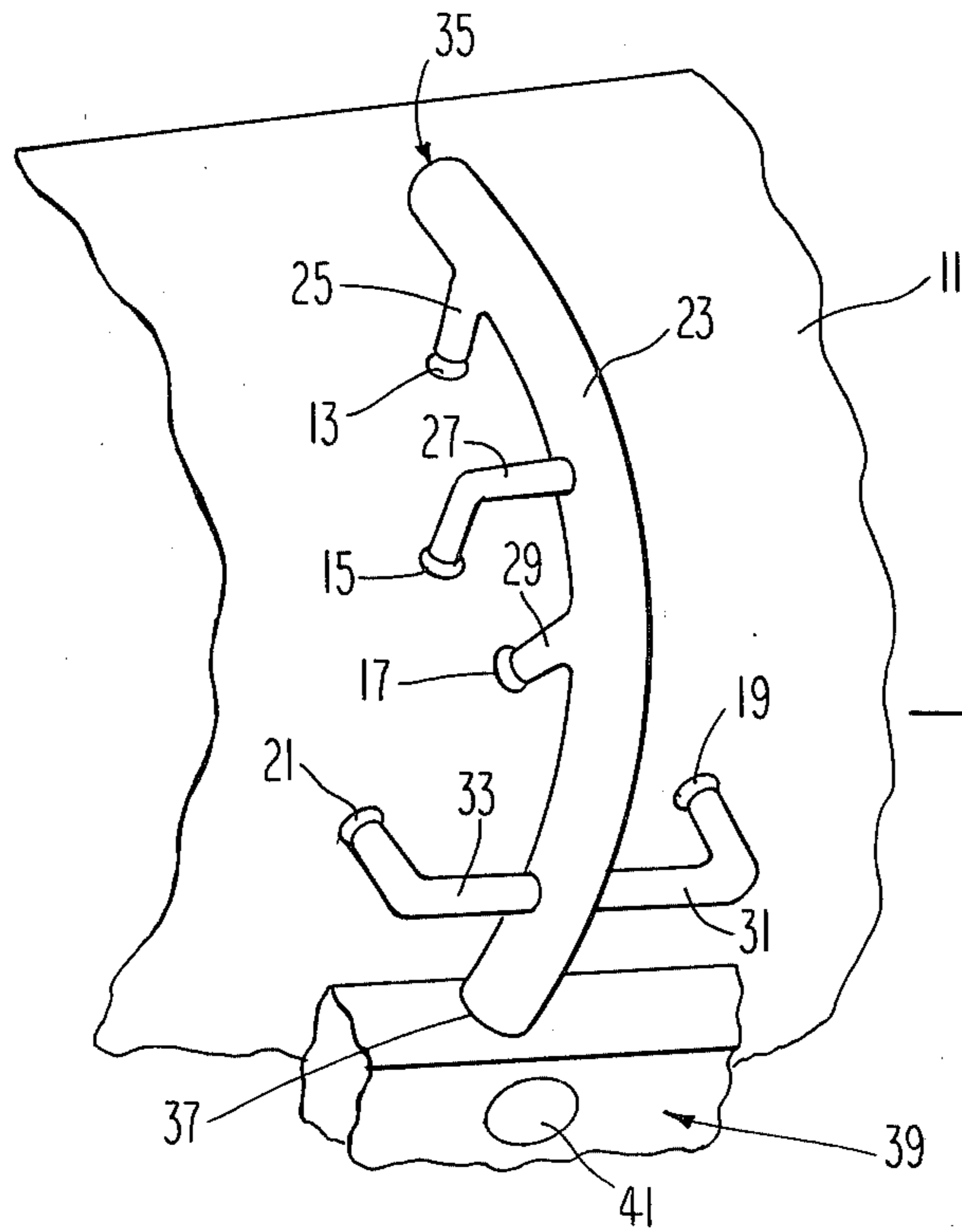

PRIOR ART

**Fig. 1**

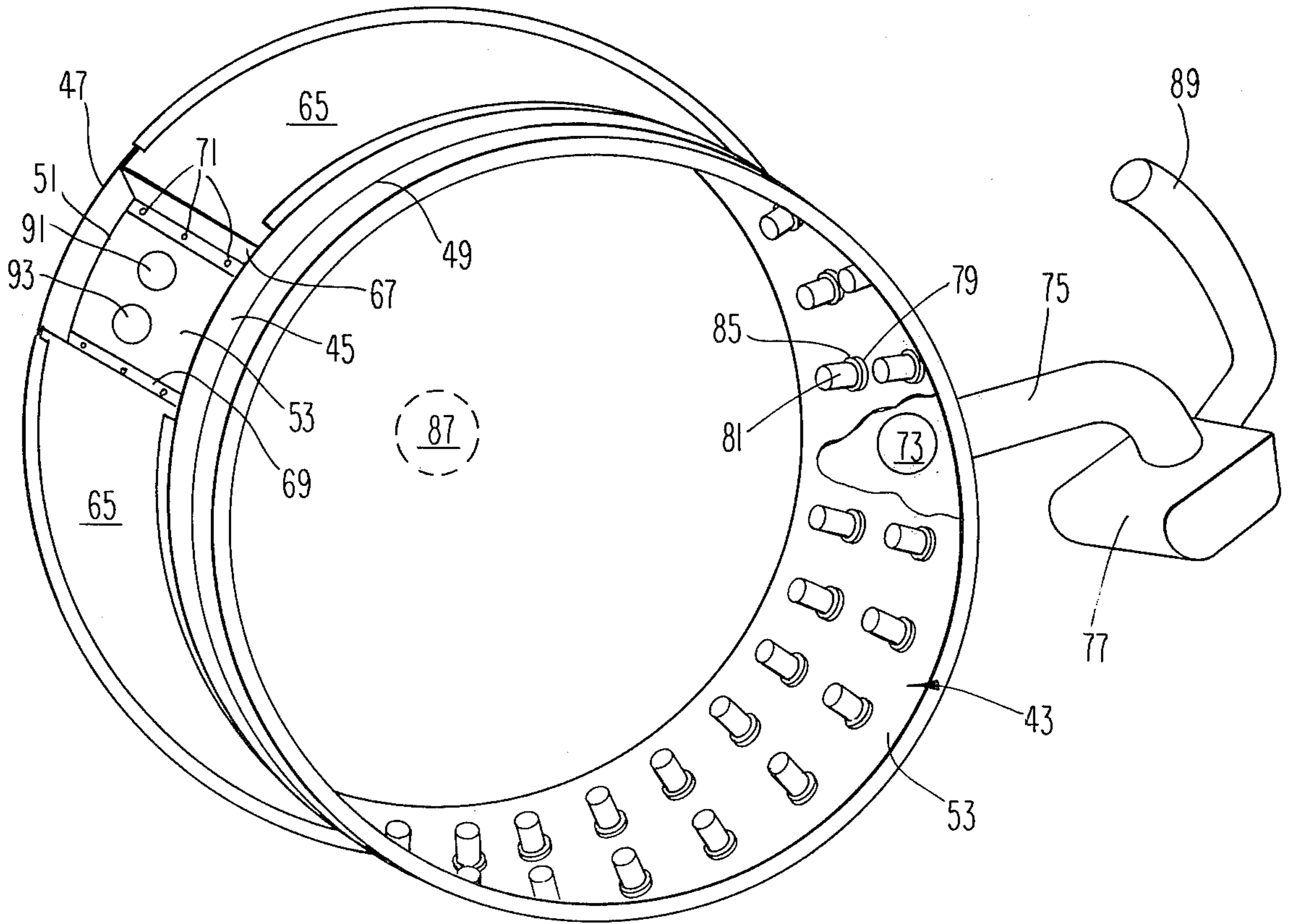

**Fig. 2**

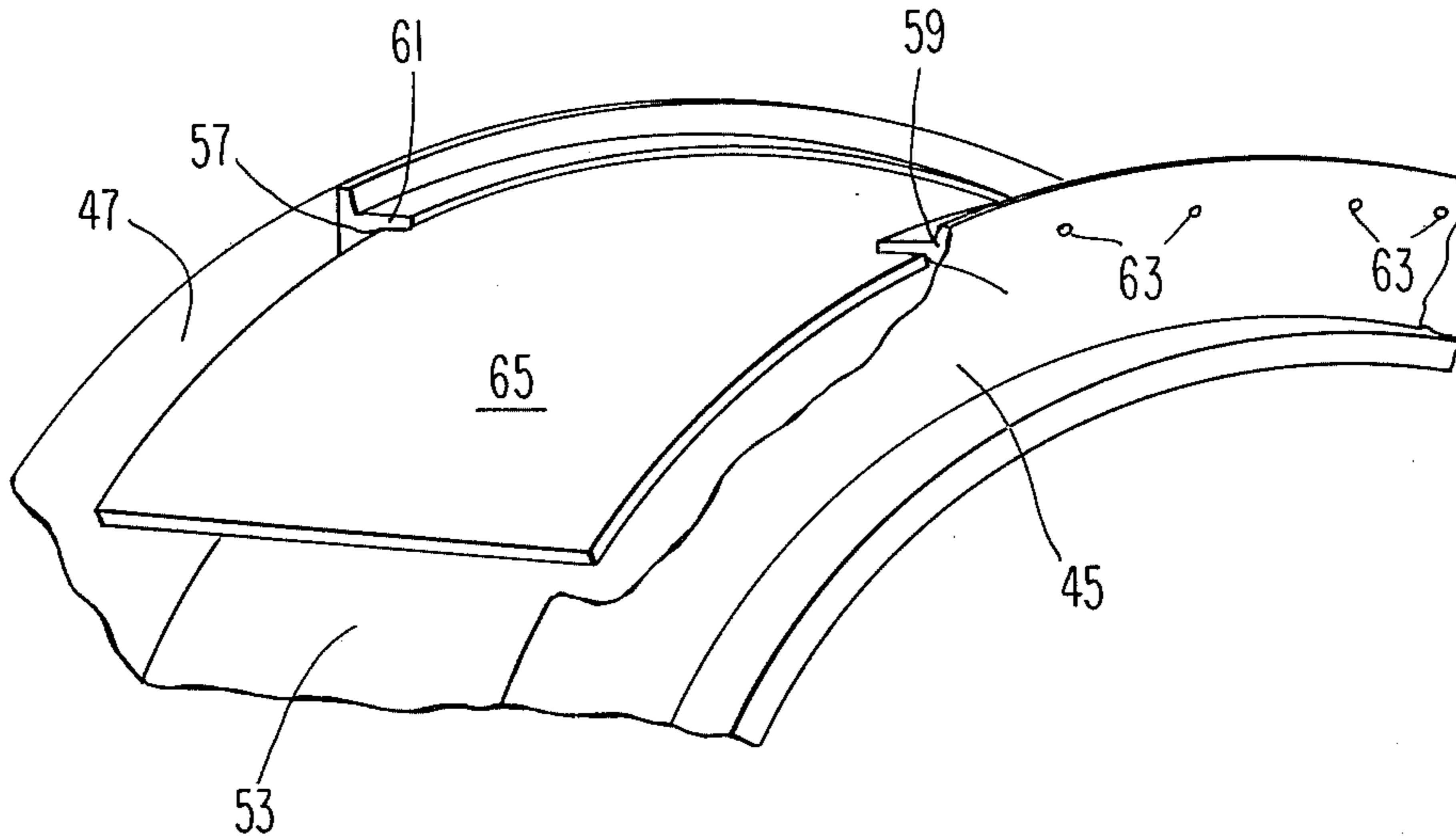

**Fig. 3**

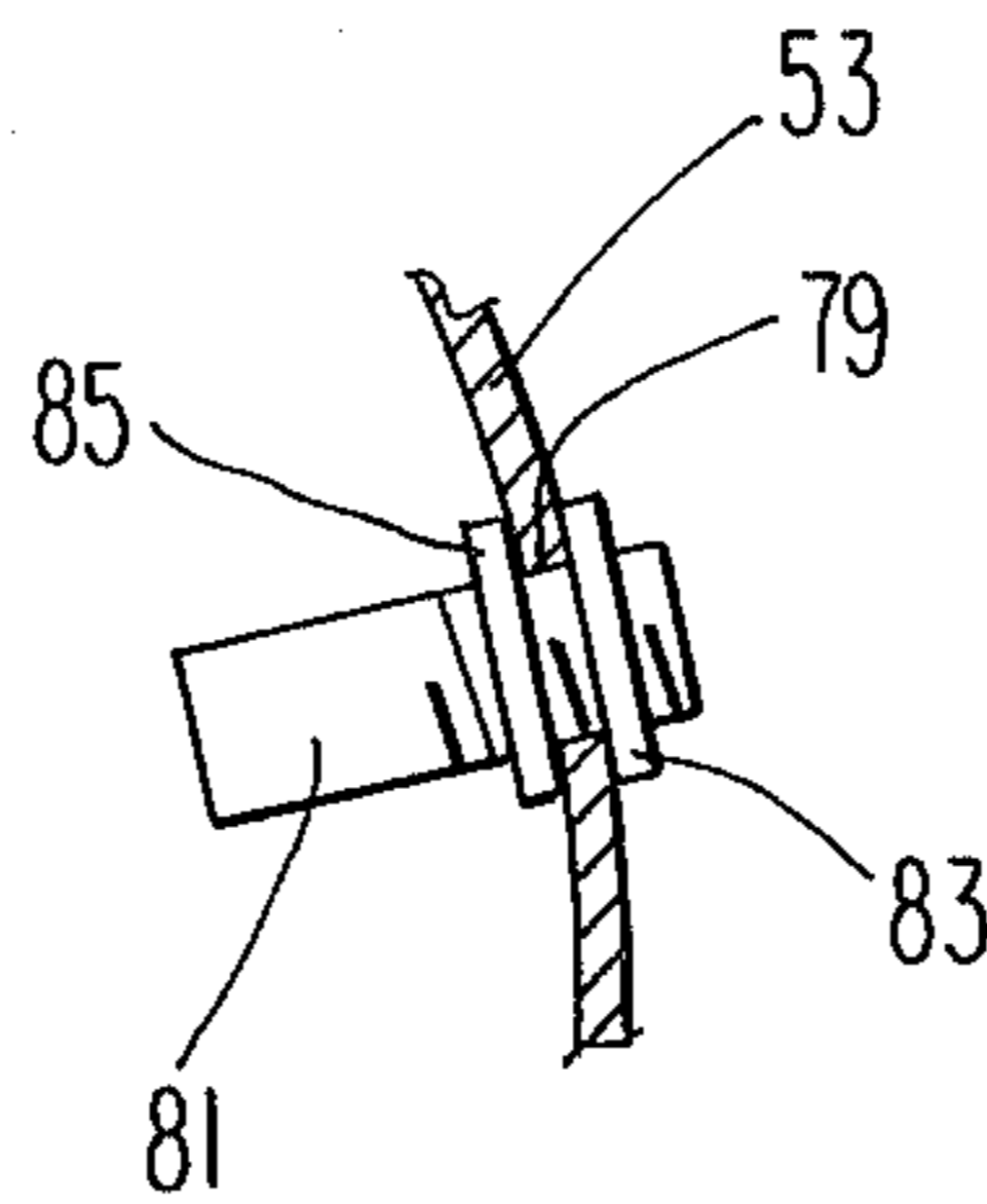

**Fig. 4**

CAS DUCT ARRANGEMENT FOR A MACHINE

groove, or a race, formed therein. The two side wall

nected into a manifold means such as manifold means  
22 71

ends of the duct formed by the sheet metal piece 65, side  
walls 45 and 47 and outer wall 52

plenum means formed and disposed to fit substantially side walls and of substantially the same length as said